

MHD 21 B 37 R 2 CP 12

21 cm - 8"

BASS MIDRANGE

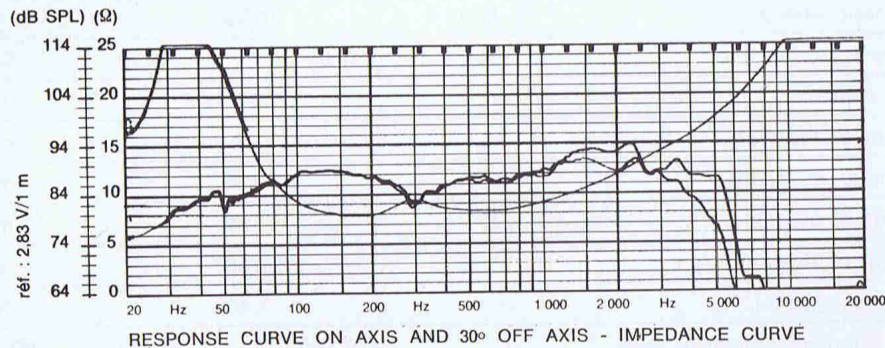
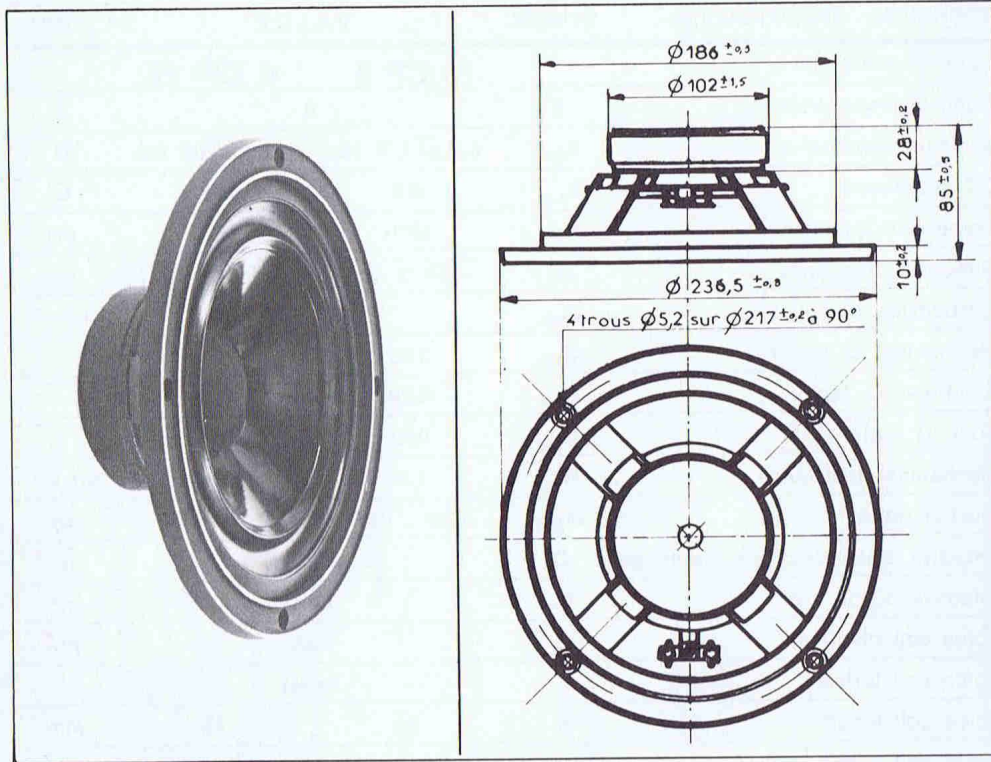

Same specifications as MHD 21 B 25 J-2 CP 9.
1 1/2" voice coil for higher power handling.

MHD 21 B 37 R 2 CP 12

21 cm - 8"

TECHNICAL SPECIFICATION	SYMBOL	VALUE	UNIT
Nominal impedance	Z	8	Ω
Minimum impedance	Z _{min}	8 @ 175 Hz	Ω
DC resistance	R _{scc}	6,9	Ω
Voice coil inductance	L _{BM}	850	μH
Resonant frequency	f _s	27,4 ± 4	Hz
Suspension compliance	C _{MS}	1,47 · 10 ⁻³	mN ⁻¹
Mechanical Q factor	Q _{MS}	3,52	
Electrical Q factor	Q _{ES}	0,38	
Total Q factor	Q _{TS}	0,34	
Mechanical resistance	R _{MS}	1,10	kg s ⁻¹
Moving mass	M _{MD}	22,8 · 10 ⁻³	kg
Emissive diameter of the diaphragm	D	0,16	m
Effective piston area	S _D	0,020	m ²
Voice coil diameter	d	38,1	mm
Voice coil former		Paper	
Voice coil length	h	12	mm
Voice coil layers	n	2	
Flux density	B	1,20	T
Flux in the Gap	∅	0,720 · 10 ⁻³	Wb
Magnetic energy	W	0,436	Ws
Force factor	BL	8,50	NA ⁻¹
Gap volume	V _E	0,761 · 10 ⁻⁶	m ³
Height of the Gap	H _E	5	mm
Diameter of magnet	∅ A	102	mm
Height of magnet	B	18	mm
Weight of magnet		0,560	kg
Mass of speaker		1,460	kg
Characteristic efficiency level :			
1 W, pink noise, weighted	η	89 (W)	dB SPL
Nominal power handling		40	W
Acceleration factor	Γ	373	ms ⁻² A ⁻¹